

BL 20 JC

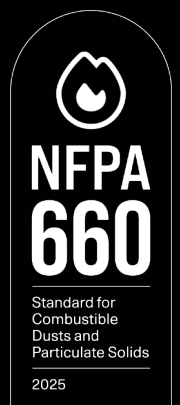

Controlled Air Design
Raleigh, NC
(800) 635-0298
controlledairdesign.com



Depureco Industrial Vacuums USA

19121 Marketplace Avenue, Building 1, Suite 165
Plum Creek Business Park • Kyle • TX 78640

www.depurecousa.com
info@depurecousa.com

POWER 1.5 HP

FILTER 5,270 in²

CAPACITY 5 gal



Head with double stage filtration system.

BRUSHLESS MOTOR
120 V

PRESSURE GAUGE
Dirty filter indicator

M CLASS ANTISTATIC CARTRIDGE FILTER

(OPTIONAL) FILTER CARTRIDGE HEPA H14

JET CLEAN CLEANING SYSTEM
Clean the filter with a powerful jet of air without stopping the unit.

ALL COMPONENTS ARE GROUNDED

STAINLESS STEEL BIN
AISI 304
5 GAL

SPEC SHEET

	Units	BL 20 JC
Suction type		Brushless motor
Power	HP	1,5
Voltage Frequency	V Hz	120 50
Maximum vacuum	inH2O	92
Maximum air flow	CFM	129
Inlet	Ø in	2
Noise level - (EN ISO 3744)	dB(A)	72
Bin capacity	gal	5
Dimensions	in	20.32x21.46
Height	in	41.33
Weight	lb	378
Primary filter		
Type		Cartridge
Surface area	in ² in	5,270
(Class EN 60335-2-69)		M Class
Media		Antistatic polyester
Filter cleaning		Jet Clean
Absolute filter - Optional		
(Class - EN 1822)	in ²	H14
Media		Fiberglass

NORMATIVE REFERENCES

COMPLIANT TO

- NFPA 660
- NFPA 79
- UL 2011
- UL 508A
- CSA C22.2

ACCESSORIES



ANTISTATIC STARTER KIT Ø 2 in



ANTISTATIC KIT PRO Ø 2 in



SPARE FILTER CARTRIDGE HEPA H14

HIGHLY TRANSPORTABLE

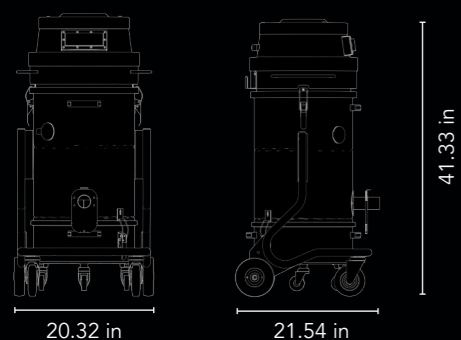

Weight: 378 lbs

COMPLIANT TO



OPTIONAL



CYCLONIC PRE-SEPARATOR