

BL 45 JC

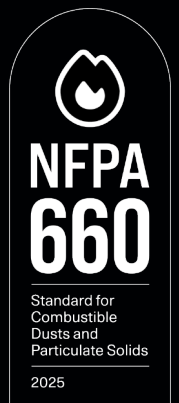

Controlled Air Design
Raleigh, NC
(800) 635-0298
controlledairdesign.com



Depureco Industrial Vacuums USA

19121 Marketplace Avenue, Building 1, Suite 165
Plum Creek Business Park • Kyle • TX 78640

www.depurecousa.com
info@depurecousa.com

1,5 HP
POWER

5270 in²
FILTER

11 gal
CAPACITY

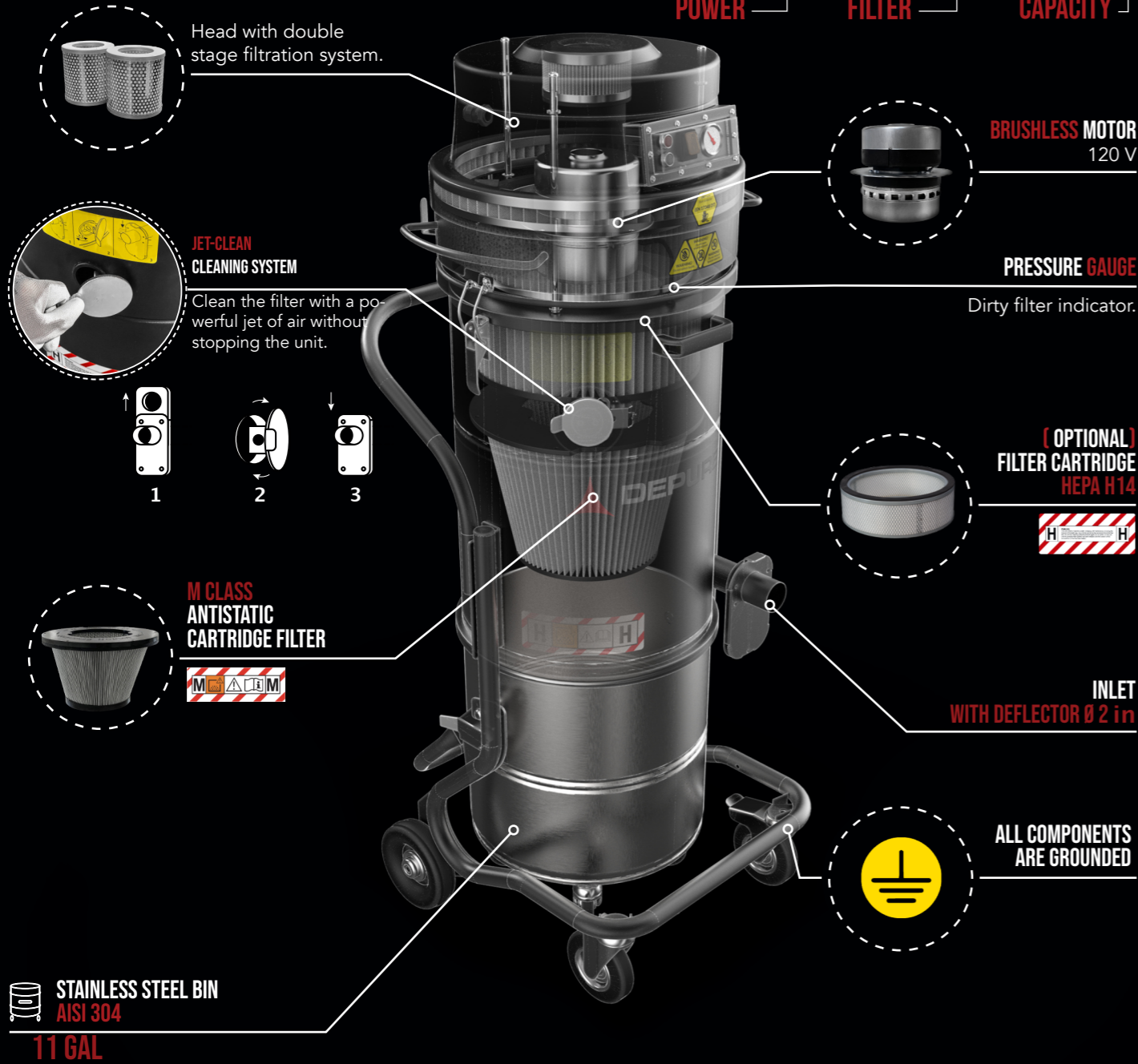

SPEC SHEET

	Units	BL 45 JC
Suction type		Brushless motor
Power	HP	2 1 ~
Voltage Frequency	V Hz	120 60
Maximum vacuum	inH2O	92
Maximum air flow	CFM	129
Inlet	Ø in	2.75
Noise level - (EN ISO 3744)	dB(A)	72
Bin capacity	gal	11
Dimensions	in	21.46 x 20.32
Height	in	51.29
Weight	lb	99
Primary filter		
Type		Cartridge
Surface area	in ² in	6200
(Class EN 60335-2-69)		M Class
Media		Antistatic polyester
Filter cleaning		Jet-Clean
Absolute filter - Optional		
(Class - EN 1822)	in ²	H14
Media		Fiberglass
In suction		Opt H14
In suction		E10
Engine air inlet cooling	in ²	E10
Outgoing engine air cooling		E10

NORMATIVE REFERENCES

COMPLIANT TO

- NFPA 660
- NFPA 79
- UL 2011
- UL 508A
- CSA C22.2

ACCESSORIES



ANTISTATIC STARTER KIT Ø 2 in



ANTISTATIC KIT PRO Ø 2 in



FILTER CARTRIDGE HEPA H14

HIGHLY TRANSPORTABLE

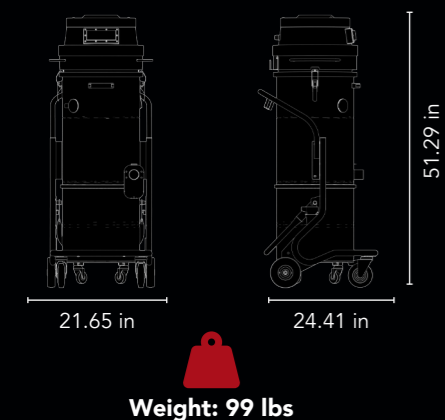

COMPLIANT TO



OPTIONAL



CYCLONIC PRE-SEPARATOR



Wet & Dry fixed brush floor tool