

# IperJet DF ATEX Compliant 3DST1



CE II 3DST1 Independently tested  
according to regulation 2014/34/EU

Filter suitable for organic and inorganic dust - NOT metallic



## Iperjet DF ATEX Compliant 3DST1

- Iperjet DF 4-6-9 3DST1 OUTDOOR
- Iperjet DF 4-6-9 3DST1 INDOOR
- Iperjet DF 4-6-9 3DST1 TRU OUTDOOR
- Iperjet DF 4-6-9 3DST1 TRU INDOOR

# Design

Atex Compliant version of the Iperjet range. It can have 4, 6 or 9 horizontal cartridges for suction and filtration of flammable or explosive vapours and dust. Reliable and robust due to its panel construction.

## IperJet DF ATEX Compliant 3DST1

12 Models

### QBox

INDOOR VENT  
explosion  
venting system Mod.  
INDOOR.



### Soundproofing plenum and absolute filter

Soundproofing plenum and  
HEPA filter H13.

### Control panel

To CE standards  
remotely located  
about 5 metres away  
in a non Atex zone.

## Highlights

- **Atex compliant:** suitable for environments with pollutants at risk of fire and explosion.
- Durable **panelled structure.**
- **Plug & Play' solution,** no installation required.
- **Automatic** air jet cleaning **system.**
- Filtration of welding fumes and sanding dust of **non-metallic** products **from mechanical industry processes**

## Applications



Organic and inorganic dust - NOT metallic

# Principle of operation

The IperJet DF filter unit consists of a pre-chamber, where most of the fumes and coarse dust are separated and deposited in the first and second collection bin; the subsequent labyrinth and filter section with high-efficiency M-class cartridges filter the air before it is returned to the room. The high-efficiency fan at the top of the unit guarantees high suction capacity and low noise. Cartridges are cleaned by an automatic compressed air cleaning system.

Iperjet DF

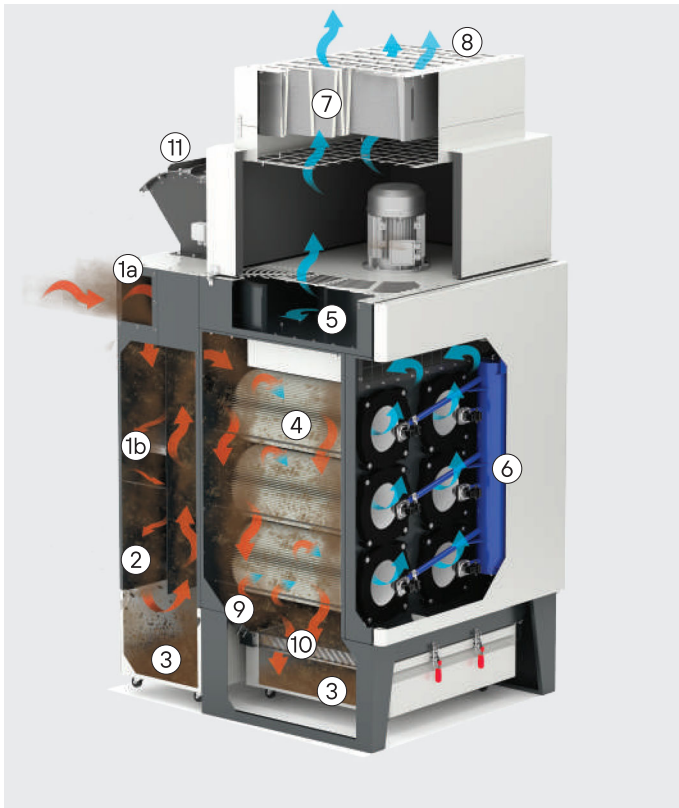

Iperjet DF



- ①a Dusty air inlet
- ①b Spark extinguisher mod.css
- ② First Pre-chamber (coarse dust)
- ③ Collection bins
- ③a front collection bin
- ④ Filter cartridges
- ⑤ Fan
- ⑥ Compressed air tank
- ⑦ Soundproofing plenum and HEPA filter (indoor)
- ⑧ Filtered air outlet
- ⑨ Second pre-chamber
- ⑩ Dust separation grille front bin
- ⑪ INDOOR-VENT explosion venting system  
Mod. INDOOR
- ⑫ Venting panel

Indoor



Outdoor



# Product range

## Iperjet DF Outdoor



The filter unit is complete with IFA/BGIA M PES/AX EXAM accredited horizontal antistatic cartridges, venting panel, compressed air cleaning system, electrical panel separated from the machine with 5 m of pre-wired cable, ATEX coil and matrix cable, oversized inlet with spark extinguishing system, ATEX motor, double reinforced dust collection box with dust separation grille front bin. It is advisable to protect it from the weather.

Cartridges (nr)	Power (kW)
4	3   2.2
6	4
9	7.5

## Iperjet DF Indoor



The filter unit is complete with IFA/BGIA M PES/AX EXAM accredited horizontal antistatic cartridges, soundproofing box and HEPA filter, Indoor-vent explosion venting system, compressed air cleaning system, electrical cabinet separated from the machine with 5 m of pre-wired cable, ATEX coil and matrix cable, oversized inlet with spark extinguishing system, ATEX motor, double reinforced dust collection box, with dust separation grille front bin explosion control system

Cartridges (nr)	Power (kW)
4	3   2.2
6	4   5,5
9	7,5   11

## Iperjet DF TRU Outdoor



The filter unit is complete with IFA/BGIA M PES/AX EXAM accredited horizontal antistatic cartridges, venting panel, compressed air cleaning system, electrical panel separated from the machine with 5 m of pre-wired cable, ATEX coil and matrix cable, oversized inlet with spark extinguishing system, ATEX motor, with a single hopper and collection bin for easy and quick discharge of filtered dust. Double reinforced dust collection box with dust separation grille front bin. It is advisable to protect it from the weather.

Cartridges (nr)	Power (kW)
4	3   2.2
6	4   5,5
9	7,5   11

## Iperjet DF TRU Indoor



The filter unit is complete with IFA/BGIA M PES/AX EXAM accredited horizontal antistatic cartridges, soundproofing box and HEPA filter, Indoor-vent explosion venting system, compressed air cleaning system, electrical cabinet separated from the machine with 5 m of pre-wired cable, ATEX coil and matrix cable, oversized inlet with spark extinguishing system, ATEX motor, with a single hopper and collection bin for easy and quick discharge of filtered dust. Double reinforced dust collection box, with dust separation grille front bin explosion control system

Cartridges (nr)	Power (kW)
4	3   2.2
6	4   5,5
9	7,5   11

# Standard Components

OUTDOOR | INDOOR



Filter cartridge IFA/BGIA M PES / AX EXAM

OUTDOOR | INDOOR



ATEX electric motor

**ATEX EX II 3GD c EEx nA IIC IP55 T3 - zone 2**

OUTDOOR | INDOOR



Matrix ATEX solenoid and cable

OUTDOOR

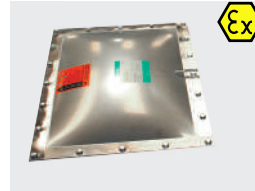

Venting panel

INDOOR

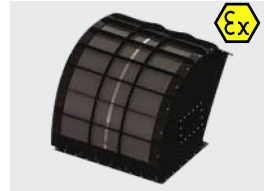

Explosion control system

OUTDOOR | INDOOR



Rear collection bin

OUTDOOR | INDOOR



Front collection bin

OUTDOOR | INDOOR



Dust separation grille front bin

OUTDOOR | INDOOR



Compressed air cleaning system

OUTDOOR | INDOOR



Control panel separated from the machine with 5 m of pre-wired cable

OUTDOOR | INDOOR



Enlarged inlet with spark extinguishing system

INDOOR

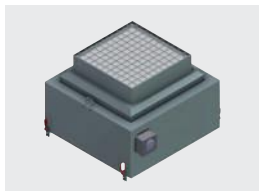

Soundproofing plenum and HEPA filter H 13 (optional H 14)

# Options

OUTDOOR | INDOOR



linlet connection

OUTDOOR | INDOOR

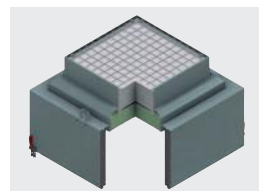

Soundproofed plenum with active carbon

OUTDOOR

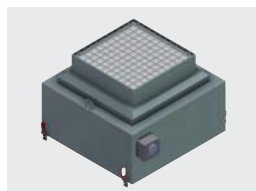

Soundproofing plenum and HEPA filter H 13 (optional H 14)

OUTDOOR | INDOOR



Fire extinguisher to be defined according to application

OUTDOOR | INDOOR



Control panel separated from the machine with 5 m of pre-wired cable with inverter

# Technical features

Technical features		Model IperJet ATEX Compliant 3DST1					
		4   4 TRU		6   6 TRU		9   9 TRU	
Power	kW	2,2	3	4	5,5	7,5	11
Nominal Air Flow	m <sup>3</sup> /h	2000	3000	4000	5500	6500	7500
Number of cartridge filter	Ø325 mm H 750 mm	4	4	6	6	9	9
Filtering Surface	m <sup>2</sup>	48	48	72	72	108	108
Cartridge classification		M PES /AX/ EXAM ACCREDITED					
Pneumatic cleaning		YES		YES		YES	
Bin holding capacity (A+B)	lt	80/123		90/146		102/188	
DF TRU	lt	65		65		65	
R.P.M.		2865	2895	2900	2960	2915	2980
Fan Voltage STD	V	230/400		230/400		230/400	
	Hz	50		50		50	
Average noise level OUTDOOR	dB	76	78	80	81	83	85
Average noise level INDOOR	dB	68	71	72	74	76	78
Total weight OUTDOOR	kg	450	460	550	570	752	800
Total weight INDOOR	kg	530	545	600	620	874	925
Available Static inlet pressure OUTDOOR	mmH <sub>2</sub> O	100	130	100	110	130	170
Available Static inlet pressure INDOOR	mmH <sub>2</sub> O	85	100	70	80	100	140
Working tank header pressure		MAX 8 Bar					
Pipe air speed		5"		5"		5"	
Solenoid valves		4 x (3/4")		6 x (3/4")		9 x (3/4")	

# Overall dimensions

## Outdoor

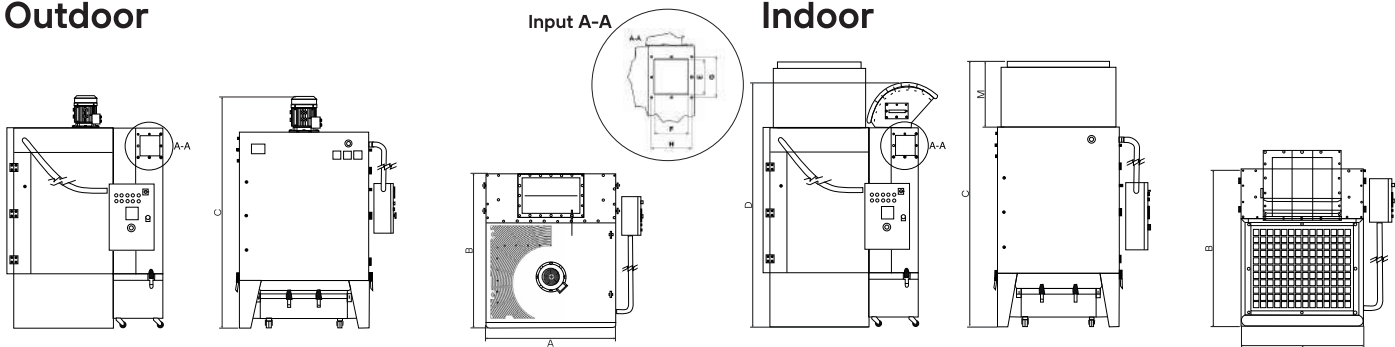

## TRU Outdoor

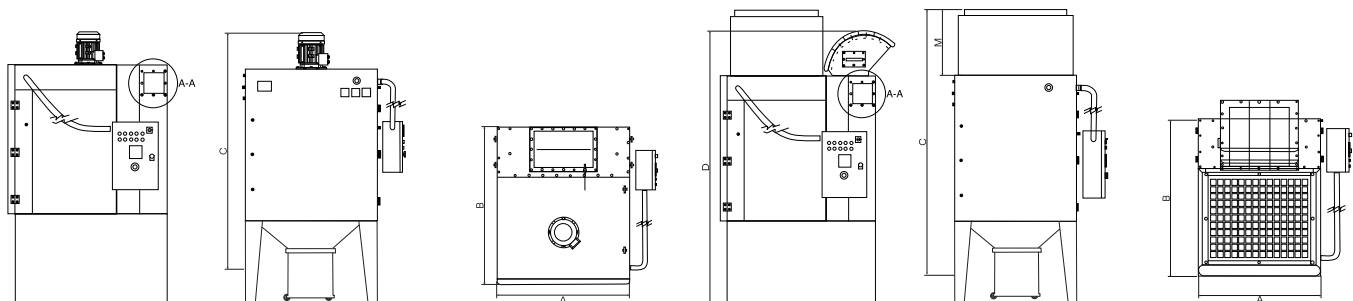

## TRU Indoor

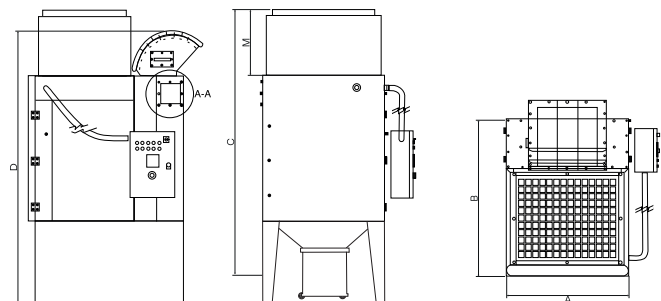

# Overall dimensions

MODEL	DIMENSIONS (mm)					
	A	B	Outdoor C	Indoor C	Indoor D	Indoor M
Iperjet <b>DF 4</b>	930	1400	1915	2290	2015	680
Iperjet <b>DF 6</b>	1100	1420	2130	2485	2200	680
Iperjet <b>DF 9</b>	1300	1540	2340	2771	2390	792
Iperjet <b>DF 4 TRU</b>	928	1416	2210	2598	2367	680
Iperjet <b>DF 6 TRU</b>	1100	1420	2380	2802	2569	680
Iperjet <b>DF 9 TRU</b>	1300	1540	2695	2773	2780	792

MODEL Input	DIMENSIONS (mm)			
	E	F	G	H
Iperjet <b>DF 4</b>	180	180	210	210
Iperjet <b>DF 6</b>	180	180	210	210
Iperjet <b>DF 9</b>	220	180	250	210
Iperjet <b>DF 4 TRU</b>	180	180	210	210
Iperjet <b>DF 6 TRU</b>	180	180	210	210
Iperjet <b>DF 9 TRU</b>	220	180	250	210

## Packaging information



MODEL	DIMENSIONS (mm) AxBxH	WEIGHT (kg)
Iperjet <b>DF 4 outdoor</b>	1550 x 1400 x 2100	430
Iperjet <b>DF 4 indoor</b>	1550 x 1400 x 2100	430
Iperjet <b>DF 6 outdoor</b>	1550 x 1400 x 2250	580
Iperjet <b>DF 6 indoor</b>	1750 x 1400 x 2300	620
Iperjet <b>DF 9 outdoor</b>	1750 x 1750 x 2250	790
Iperjet <b>DF 9 indoor</b>	1900 x 1750 x 2400	890
Iperjet <b>DF 4 TRU outdoor</b>	1400 x 1150 x 2450	490
Iperjet <b>DF 4 TRU indoor</b>	1400 x 1150 x 2450	490
Iperjet <b>DF 6 TRU outdoor</b>	1400 x 1400 x 2700	640
Iperjet <b>DF 6 TRU indoor</b>	1400 x 1400 x 2700	640
Iperjet <b>DF 9 TRU outdoor</b>	3000 x 1800 x 1500	890
Iperjet <b>DF 9 TRU indoor</b>	3000 x 1800 x 1500	890

MODEL Soundproofing plenum	DIMENSIONS (mm) AxBxH	WEIGHT (kg)
Iperjet <b>DF 4 indoor</b>	940 x 940 x 850	70
Iperjet <b>DF 6 indoor</b>	1200 x 1000 x 850	90
Iperjet <b>DF 9 indoor</b>	1400 x 1150 x 1000	115



# Made in Coral

Coral manufactures 100% of all the components that are part of an industrial extraction system within their facilities in Volpiano, just outside of Turin. The quality of materials that we use and our industry experience guarantee a production of high level in everything we make.

## ITALIA

MILANO	p: +39 02 95.30.1003
TORINO	p: +39 011 99.80.141
VICENZA	p: +39 0444 34.93.98
BOLOGNA	p: +39 051 69.26.335

## FRANCE

LYON	p: +33 4 74 944 562
PARIS	p: +33 1 60 868 069
POITIERS	p: +33 5 49 379 596

## GERMANY

LEVERKUSEN	p: +49.214.312.663.20
------------	-----------------------

## UNITED KINGDOM

LITTLEBOROUGH ROCHDALE	p: +44 1 706 377344
------------------------	---------------------

## MIDDLE EAST

DUBAI UAE	p: +971 56 1028130
-----------	--------------------

## INDIA

BANGALORE	p: +91 734 888 2333 - 2777
-----------	----------------------------

## SINGAPORE

SINGAPORE	p: +65 88338991
-----------	-----------------

## U.S.A.

KYLE, TX	p: +1 480 796 5352
----------	--------------------



**CORAL s.p.a.**

Corso Europa, 597 10088  
Volpiano (Torino) ITALY

p: +39 011 98.22.000

e: [info@coral.eu](mailto:info@coral.eu)

**coral.eu**