

SILICA SERIES**Lifetime™ LTS85 Silica Vacuum**

World's Most Durable Bagging Type Vac

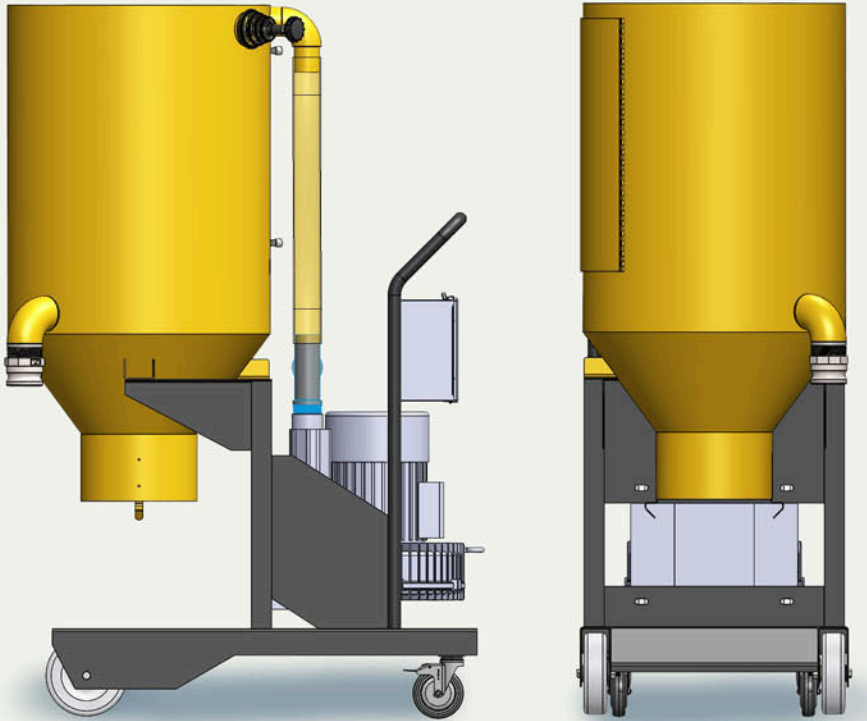

- Discharges collected material into an engineered control bag system.
- Filters so good they last years, not months. Low, low cost of operation.
- HEPA filter built-in and designed for safe use with silica based materials.



The Lifetime™ LTS85 Silica Vacuum almost never needs maintenance even in heavy industrial places.

With upgraded steel and filters that last ten times longer than everyone else, you'll get a vacuum with a low, low cost of ownership. An 8.5 Hp motor is perfect for heavy cleaning of heavy silica like sand even with 50 ft long hoses.

Meet OSHA laws with a rugged silica vac by DuroVac.



The DuroVac Lifetime LTS85 is a portable silica bagging vacuum that lasts.

TRIPLE FILTRATION means hassle-free operation when you're handling fine powders. At 99.9% efficiency, the primary filter media won't easily clog, so performance never drops as the hopper fills. Vacuum continuously without stopping the system to shake the filters.

- First-stage impaction separator with internal baffle plate to protect against abrasion
- Large main filter in a baghouse-type format.
- 99.97% HEPA filter for silica safe operation

Specifications

Model Number	LTS85
Power	8.5 Hp
Number of Hoses	1x 2.0" Up to 100 Feet
Air Flow at Inlet (CFM)	380
Vacuum Level (Maximum)	8.5" Hg.
Primary Filter Area (FT ²)	42.2
Noise Level @ 3 Ft (dbA)	85
Weight (lbs)	700

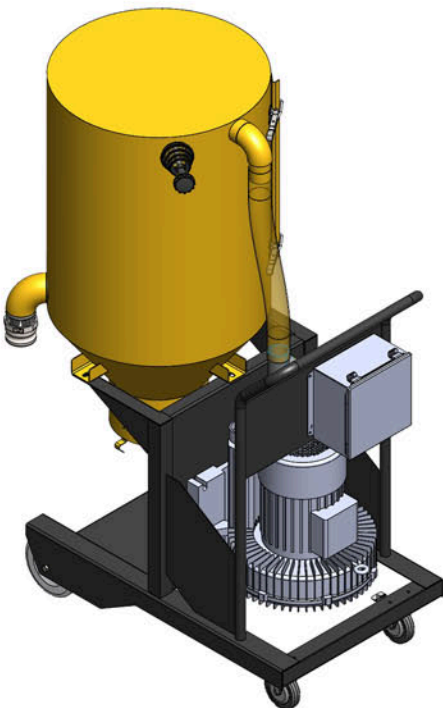

Silica safe operation with a tough little vacuum that just keeps on working.

Designed from the ground up to ensure the longest lasting filtration system, the LTS85 has more than double the primary filter area of any other vacuum in its class.

sales@durovac.com